



# Service Manual Loadall

Models:

**520-50**

from Serial No. 754001

**525-50**

from Serial No. 789308

**525-50S**

from Serial No. 1037581

PUBLISHED BY THE  
TECHNICAL PUBLICATIONS DEPARTMENT  
OF JCB SERVICE; ©

WORLD PARTS CENTRE, WATERLOO  
PARK, UTTOXETER,  
ST14 5PA, ENGLAND  
Tel. 01889 - 590312

PRINTED IN ENGLAND

Publication No. 9803/3620 Issue 9

General Information	1
Care & Safety	2
Routine Maintenance	3
Attachments	A
Body & Framework	B
Electrics	C
Controls	D
Hydraulics	E
Transmission	F
Brakes	G
Steering	H
Engine	K

---

## Introduction

This publication is designed for the benefit of JCB Distributor Service Engineers who are receiving, or have received, training by JCB Technical Training Department.

These personnel should have a sound knowledge of workshop practice, safety procedures, and general techniques associated with the maintenance and repair of hydraulic earthmoving equipment.

Renewal of oil seals, gaskets, etc., and any component showing obvious signs of wear or damage is expected as a matter of course. It is expected that components will be cleaned and lubricated where appropriate, and that any opened hose or pipe connections will be blanked to prevent excessive loss of hydraulic fluid and ingress of dirt. Finally, please remember above all else **SAFETY MUST COME FIRST!**

The manual is compiled in sections, the first three are numbered and contain information as follows:

- 1** = **General Information** - includes torque settings and service tools.
- 2** = **Care & Safety** - includes warnings and cautions pertinent to aspects of workshop procedures etc.
- 3** = **Routine Maintenance** - includes service schedules and recommended lubricants for all the machine.

The remaining sections are alphabetically coded and deal with Dismantling, Overhaul etc. of specific components, for example:

- A** = **Attachments**
- B** = **Body & Framework** ...etc.

The page numbering in each alphabetically coded section is not continuous. This allows for the insertion of new items in later issues of the manual.

Section contents, technical data, circuit descriptions, operation descriptions etc are inserted at the beginning of each alphabetically coded section.

**READ** the section contents to locate machine types, machine type identification **IS NOT** listed on individual pages.

All sections are listed on the front cover; tabbed divider cards align directly with individual sections on the front cover for rapid reference.

Where a torque setting is given as a single figure it may be varied by plus or minus 3%. Torque figures indicated are for dry threads, hence for lubricated threads may be reduced by one third.

'Left Hand' and 'Right Hand' are as viewed from the rear of the machine facing forwards.

This Service Manual covers the following machines:

**520-50** (520 N. Am.) - from Machine Serial Number 754001

**525-50** - from Machine Serial Number 789308

**525-50S** - from Machine Serial Number 1037581

<b>Contents</b>	<b>Page No.</b>
Identification	1 - 1
Torque Settings	2 - 1
Service Tools	
- Numerical List	3 - 1
- Section C	4 - 1
- Section E	5 - 1
- Section F	6 - 1
- Section H	7 - 1
- Section K	7 - 1
Sealing and Retaining Compounds	8 - 1

**Identification Plate**

Your machine has an identification plate **V** mounted as shown. The serial numbers of the machine and its major units are stamped on the plate.

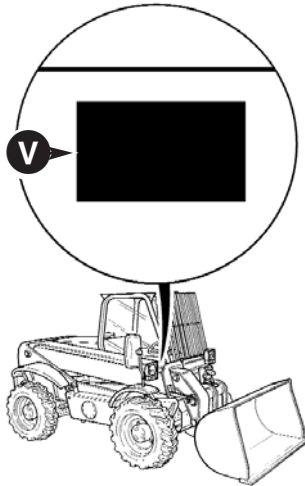

430250

**Explanation of Vehicle Identification Number (VIN)**

**SLP52050RE0754001**

**A B C D E**

<b>A</b>	World Manufacturer Identification	SLP = JCB
<b>B</b>	Machine Model	520-50
<b>C</b>	Year of Manufacture	S
	P = 1993	V = 1997
	R = 1994	W = 1998
	S = 1995	X = 1999
	T = 1996	Y = 2000
<b>D</b>	Manufacturing Location	E = England
<b>E</b>	Machine Serial Number	0754001

**Machine Model Explanation**

**520 - 50**  
**F G H**

- F** 500 Series machine range
- G** 2.0 tonnes lift capacity
- H** 5.0 metres lift height

The serial number of each major unit is also stamped on the unit itself. If a major unit is replaced by a new one, the serial number on the identification plate will be wrong. Either stamp the new number of the unit on the identification plate, or simply stamp out the old number. This will prevent the wrong unit number being quoted when replacement parts are ordered.

The machine and engine serial numbers can help identify exactly the type of equipment you have.

**Unit Identification**

The engine serial number is stamped on label **W** which is fastened to the right side of the cylinder block, near the fuel filter.

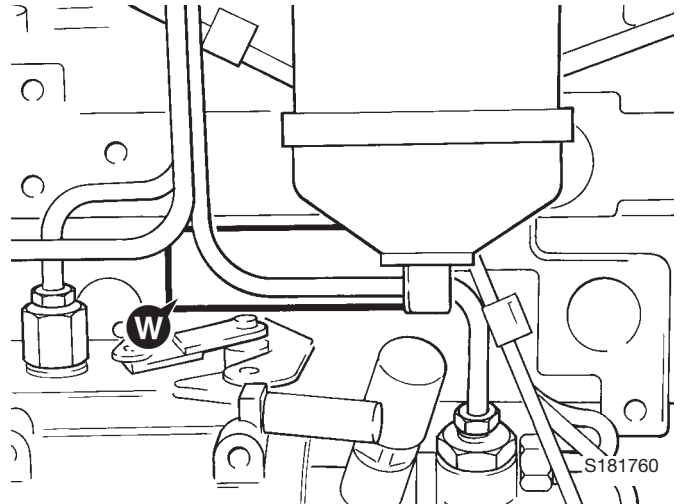

**Explanation of Engine Identification Number**

**AA 50261 U 500405 P**  
**A B C D E**

**A Engine Type:**

**A series**

- AK = 4 cylinder turbo - low emission, stage 1
- AR = 4 cylinder naturally aspirated - low emission, stage 1

**R Series**

- RE = 4 cylinder naturally aspirated, low emission, stage 2
- RG = 4 cylinder turbo, low emission stage 2
- RJ = 4 cylinder air to air charge cooled, low emission, stage 2

- B** Build Number
- C** Country of Manufacture
- D** Engine Serial Number
- E** Year of Manufacture

If service information or parts are required, the complete engine number should be quoted.

If there is also a number marked 'TPL No', this should be quoted also.

If a short engine has been fitted in service, two engine serial numbers and a TPL No. are stamped on the serial number plate as at **Z**. All the numbers should be quoted when requiring parts or information.

**Note:** Where the procedures in this manual differ according to engine types, the text and/or illustrations will specify which engine types apply.

Transmission and axle identification is shown on the next page.

The Transmission serial number is stamped on label **Y** which is mounted on the rear face.

The rear axle serial number is stamped on plate **X** mounted to the front face of the axle.

The front axle serial number is stamped on plate **Z** mounted on the rear face of the arm.

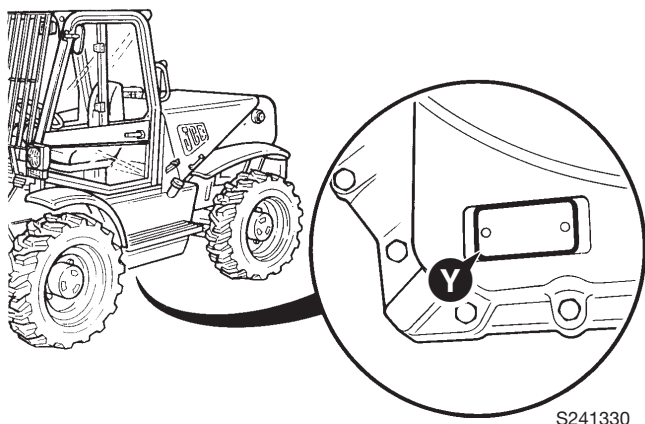

S241330

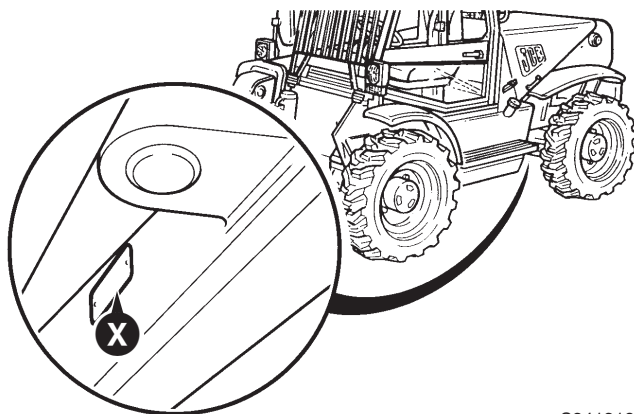

S241310

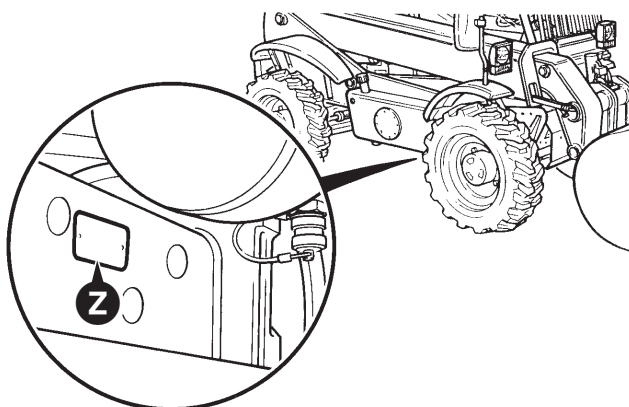

S241320

It's a preview. You can download the full file by clicking the link below.

<https://shopservicemanual.com/>

Service Manuals from 2\$