

8061

[Section 1 - General Information](#)

[Section 2 - Care and Safety](#)

[Section 3 - Maintenance](#)

[Section A - Attachments](#)

[Section B - Body and Framework](#)

[Section C - Electrics](#)

[Section D - Controls](#)

[Section E - Hydraulics](#)

[Section F - Gearboxes](#)

[Section J - Track and Running Gear](#)

[Section K - Engine](#)

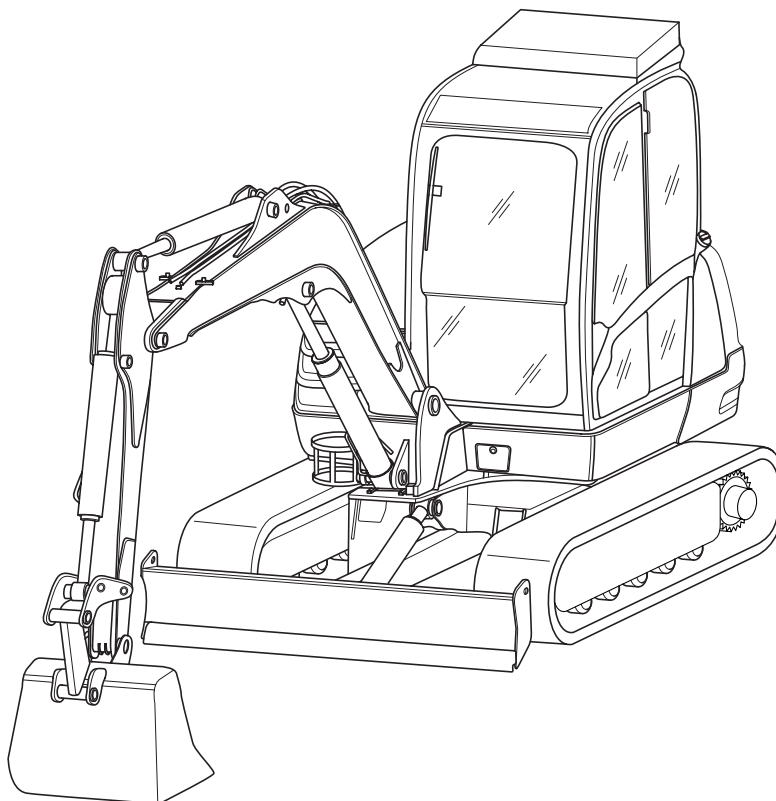

Publication No.
9813/1750-1



Copyright © 2004 JCB SERVICE. All rights reserved. No part of this publication may be reproduced, stored in a retrieval system, or transmitted in any form or by any other means, electronic, mechanical, photocopying or otherwise, without prior permission from JCB SERVICE.

Issued by JCB Technical Publications, JCB Aftermarket Training, Woodseat, Rocester, Staffordshire, ST14 5BW, England. Tel +44 1889 591300 Fax +44 1889 591400

World Class
Customer Support

General Information

[Section 1 - General Information](#)

[Section 2 - Care and Safety](#)

[Section 3 - Maintenance](#)

[Section A - Attachments](#)

[Section B - Body and Framework](#)

[Section C - Electrics](#)

[Section D - Controls](#)

[Section E - Hydraulics](#)

[Section F - Gearboxes](#)

[Section J - Track and Running Gear](#)

[Section K - Engine](#)

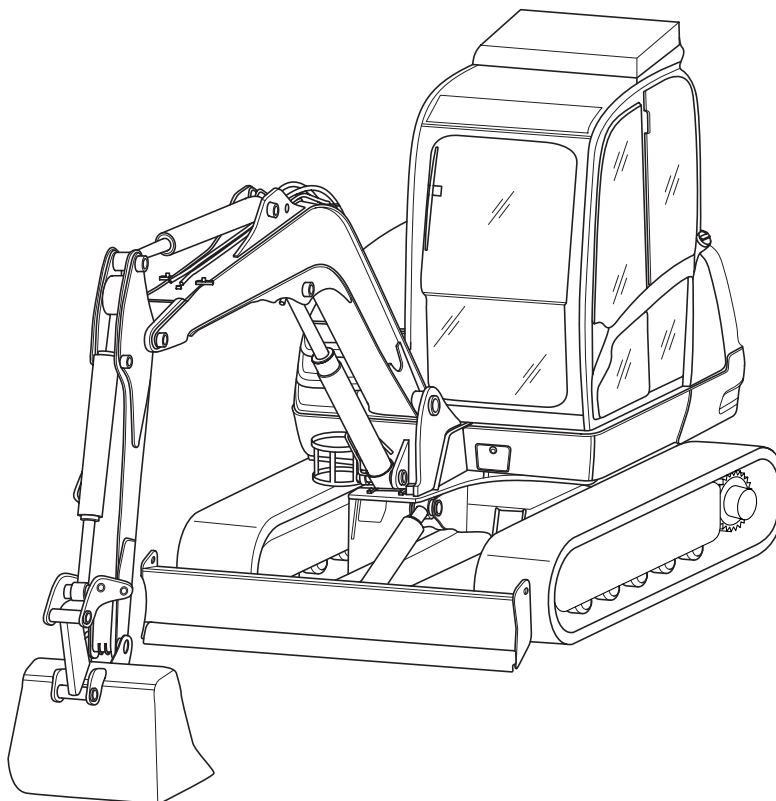

Publication No.
9813/1750-1



Copyright © 2004 JCB SERVICE. All rights reserved. No part of this publication may be reproduced, stored in a retrieval system, or transmitted in any form or by any other means, electronic, mechanical, photocopying or otherwise, without prior permission from JCB SERVICE.

Issued by JCB Technical Publications, JCB Aftermarket Training, Woodseat, Rocester, Staffordshire, ST14 5BW, England. Tel +44 1889 591300 Fax +44 1889 591400

World Class
Customer Support



Section 1 - General Information

Contents	Page No.
Introduction	
About this Publication	1 - 1
Schematic Codes	1 - 2
Identification Plates	
Identifying Your Machine	1 - 3
Standard Torque Settings	
Zinc Plated Fasteners and Dacromet Fasteners	1 - 5
Hydraulic Connections	1 - 9
Service Tools	
Numerical List	1 - 13
Tool Detail Reference	1 - 16
Service Consumables	
Sealing and Retaining Compounds	1 - 29



Section 1 - General Information

Contents

Page No.

It's a preview. You can download the full file by clicking the link below.

<https://shopservicemanual.com/>

Service Manuals from 2\$