

SHOP

MANUAL

KOMATSU

WA180-3 (EU SPEC.)

MACHINE MODEL

SERIAL NUMBER

WA180-3 (EU SPEC.)

53001 and up

- This shop manual may contain attachments and optional equipment that are not available in your area. Please consult your local Komatsu distributor for those items you may require. Materials and specifications are subject to change without notice.
- WA180-3 (EU SPEC.) mount the S6D102E-1 engine.
For details of the engine, see the 102 Series Engine Shop Manual.

CONTENTS

	No. of page
01 GENERAL	01-1
10 STRUCTURE AND FUNCTION	10-1
20 TESTING AND ADJUSTING	20-1
30 DISASSEMBLY AND ASSEMBLY	30-1
40 MAINTENANCE STANDARD	40-1
90 OTHERS	90-1

01 GENERAL

General assembly drawing	01- 2
Specifications	01- 3
Weight table	01- 6
List of lubricant and water	01- 7

GENERAL ASSEMBLY DRAWING

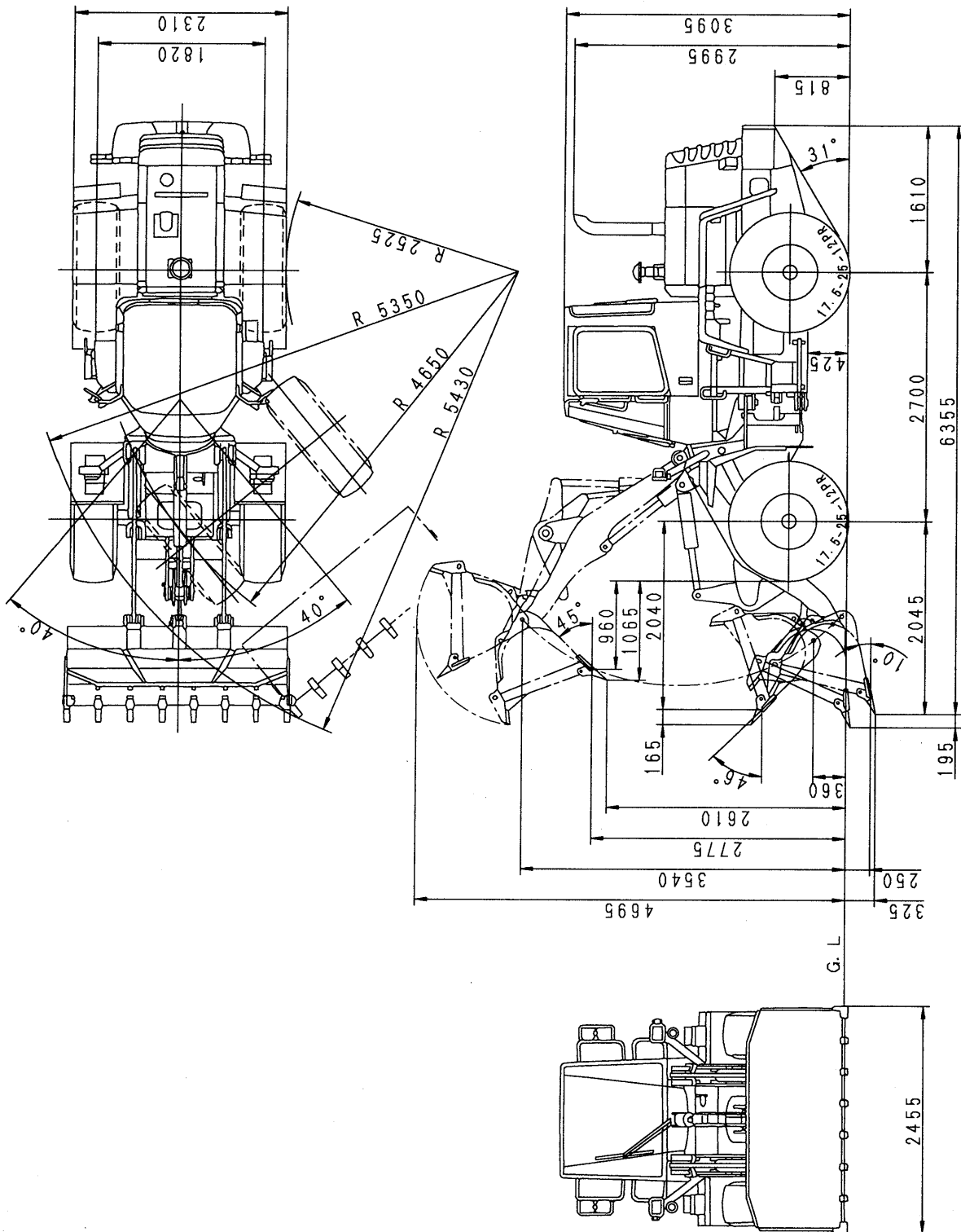

SWW02943

※ The diagram shows the values for the machine with ROPS cab.

SPECIFICATIONS

Machine model		WA180-3D		
Serial No.		53001 and up		
Weight	Operating weight	(kg)	8,900	
	Distribution (front)	(kg)	3,550	
	Distribution (rear)	(kg)	5,350	
Performance	Bucket capacity (piled) (with bolt-on teeth) (m ³)		1.6	
	Rated load (N {kg})		26,674 {2,720}	
	Travel speed	FORWARD 1st	(km/h)	7.2
		FORWARD 2nd	(km/h)	12.0
		FORWARD 3rd	(km/h)	22.0
		FORWARD 4th	(km/h)	34.5
		REVERSE 1st	(km/h)	7.7
		REVERSE 2nd	(km/h)	12.6
		REVERSE 3rd	(km/h)	22.9
		REVERSE 4th	(km/h)	35.0
	Max. rimpull (Forward) (N {kg})		81,350 {8,300}	
	(Reverse) (N {kg})		76,450 {7,800}	
	Gradeability (deg)		25	
Min. turning radius	Center of outside wheel	(mm)	4,650	
	Outside portion of chassis	(mm)	5,430	
Dimensions	Overall length (with bolt-on teeth) (mm)		6,550	
	Overall width (chassis) (mm)		2,310	
	Bucket width (mm)		2,455	
	Overall height (top of cab) (mm)		3,095	
	(Bucket raised) (mm)		4,695	
	Wheelbase (mm)		2,700	
	Tread (mm)		1,820	
	Min. ground clearance (mm)		425	
	Height of bucket hinge pin (mm)		3,540	
	Dumping clearance (tip of bucket edge) (mm)		2,775	
	(tip of bolt-on teeth) (mm)		2,610	
	Dumping reach (tip of bucket edge) (mm)		960	
(tip of bolt-on teeth) (mm)		1,065		

It's a preview. You can download the full file by clicking the link below.

<https://shopservicemanual.com/>

Service Manuals from 2\$