

MODEL 900, 906

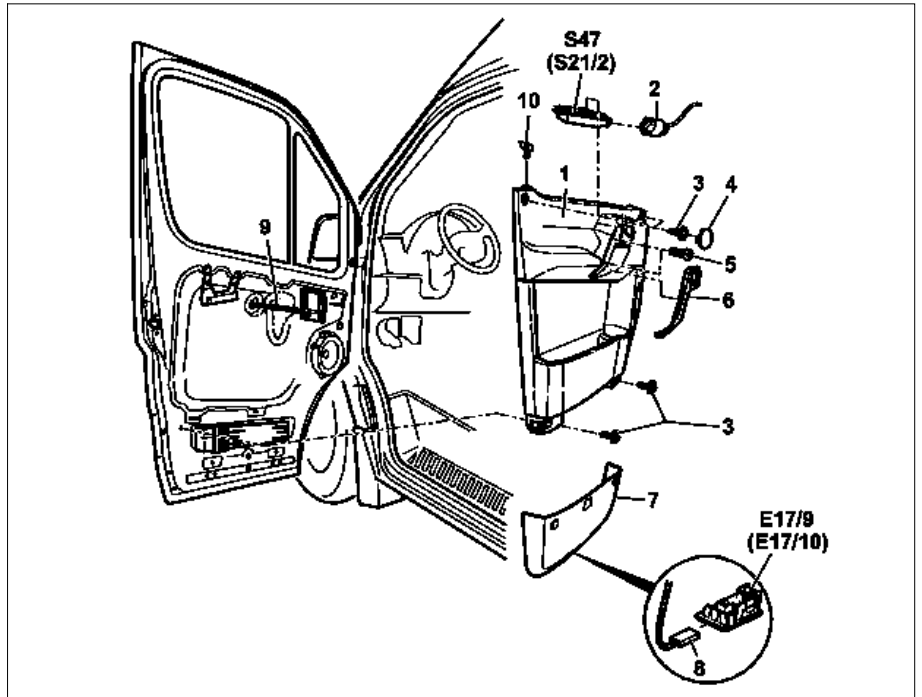

- 1 Door trim
- 2 Connector plug (with code (LB9) Illuminated exit)
- 3 Bolts
- 4 Cover
- 5 Screw
- 6 Inside door handle paneling
- 7 Door pocket
- 8 Connector plug (with code (LB9) Illuminated exit)
- 9 Inside door opener cable
- 10 Cap for inner door lock



D72.15-1125-06

- E17/9 Driver entrance/exit lamp (with code (LB9) Illuminated exit)
- E17/10 Passenger entrance/exit lamp (with code (LB9) Illuminated exit)

- S21/2 Front passenger power window switch
- S47 Driver door control panel

 	Remove/install		
1	Unclip cover (4)		
2	Remove door pocket (7)	 With code (LB9) Illuminated exit Disconnect connector plug (8) from driver entrance/exit lamp (E17/9) or passenger-side entrance/exit lamp (E17/10).	
3	Unclip inside door handle paneling (6)		
4	Unscrew bolts (3, 5) from door paneling (1)		
5	Unclip door trim (1), raise and pull away upward over lock button		
6	Unhook inside door opener cable (9)		
7	Disconnect connector (2) from driver door control panel (S47) or front passenger power window switch (S21/2)		
8	Remove door trim (1)		
9	Install in the reverse order		

## 07.3-0001 Additional designations for models and components

---

Models and components may have different versions, data and operations in the case of their 3- to 6-digit designation (e.g. 126 or 126.024). These differences are identified by the following suffixes:

Model or component designation national version	Std.	= Standard version (Std.) Identification: none
	Std. KAT	= Standard (Std.) with retrofitted, open-loop control catalytic converter Identification: none
	NV	= Low-compression engine Identification: Engine data plate (not always)
	NV KAT	= Low-compression engine with catalytic converter Identification: engine data plate
	RÜF	= Engine with "multi-functional mixture preparation and ignition system" without catalytic converter (reconverted version) Identification: On connector of EZL and KE injection=ECE
	KAT	= Engine with "multi-functional mixture preparation and ignition system" with catalytic converter Identification: on connector of EZL and KE injection=KAT
	w/o KAT	= Engine without catalytic converter (no reconversion solution) Identification: none

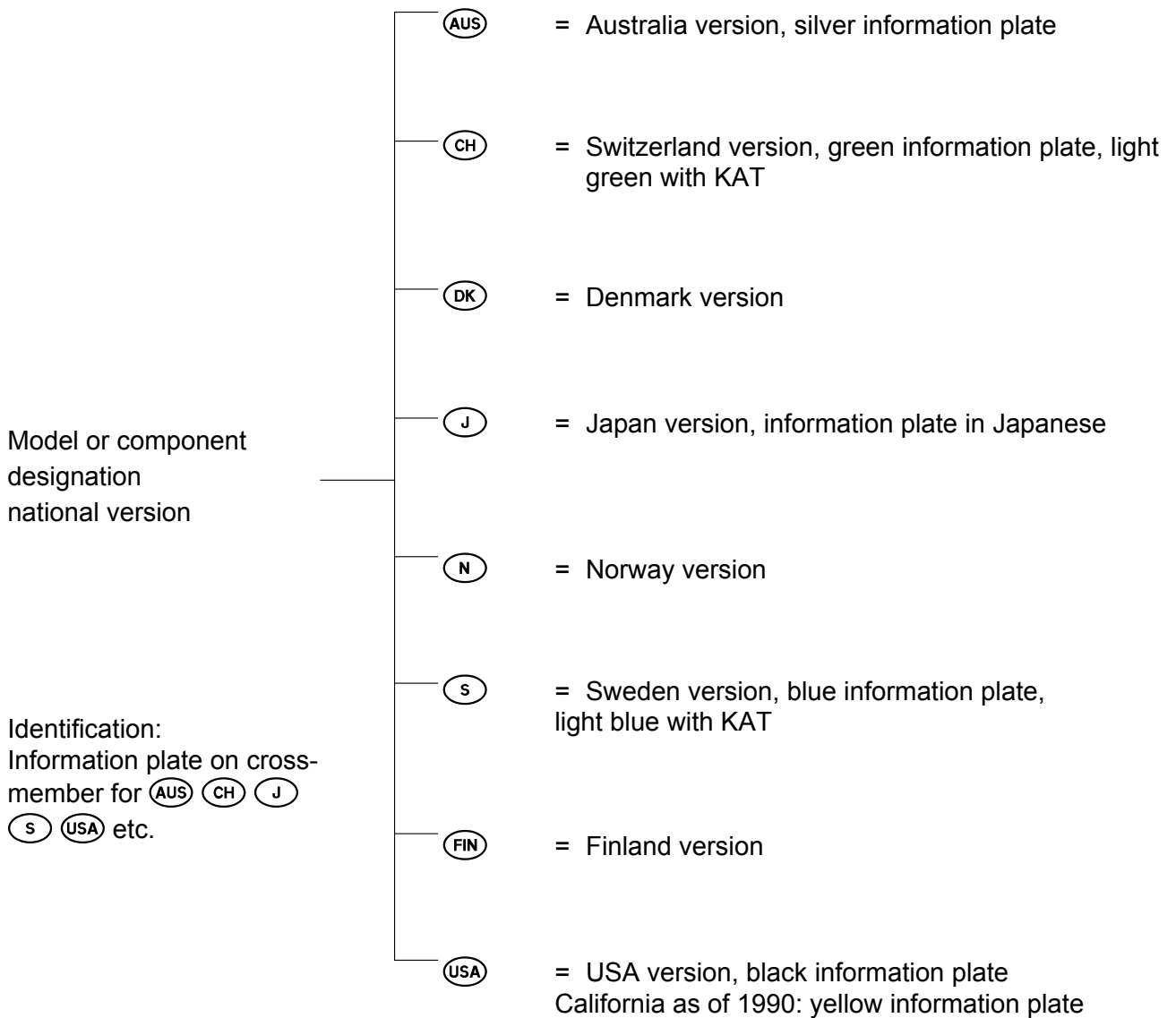

The respective model year is indicated after the nationality symbol of the national versions if necessary for distinguishing.

If no suffixes are indicated with the designation of models and components, the respective data apply to all the models and components listed in each case.

A. Model survey

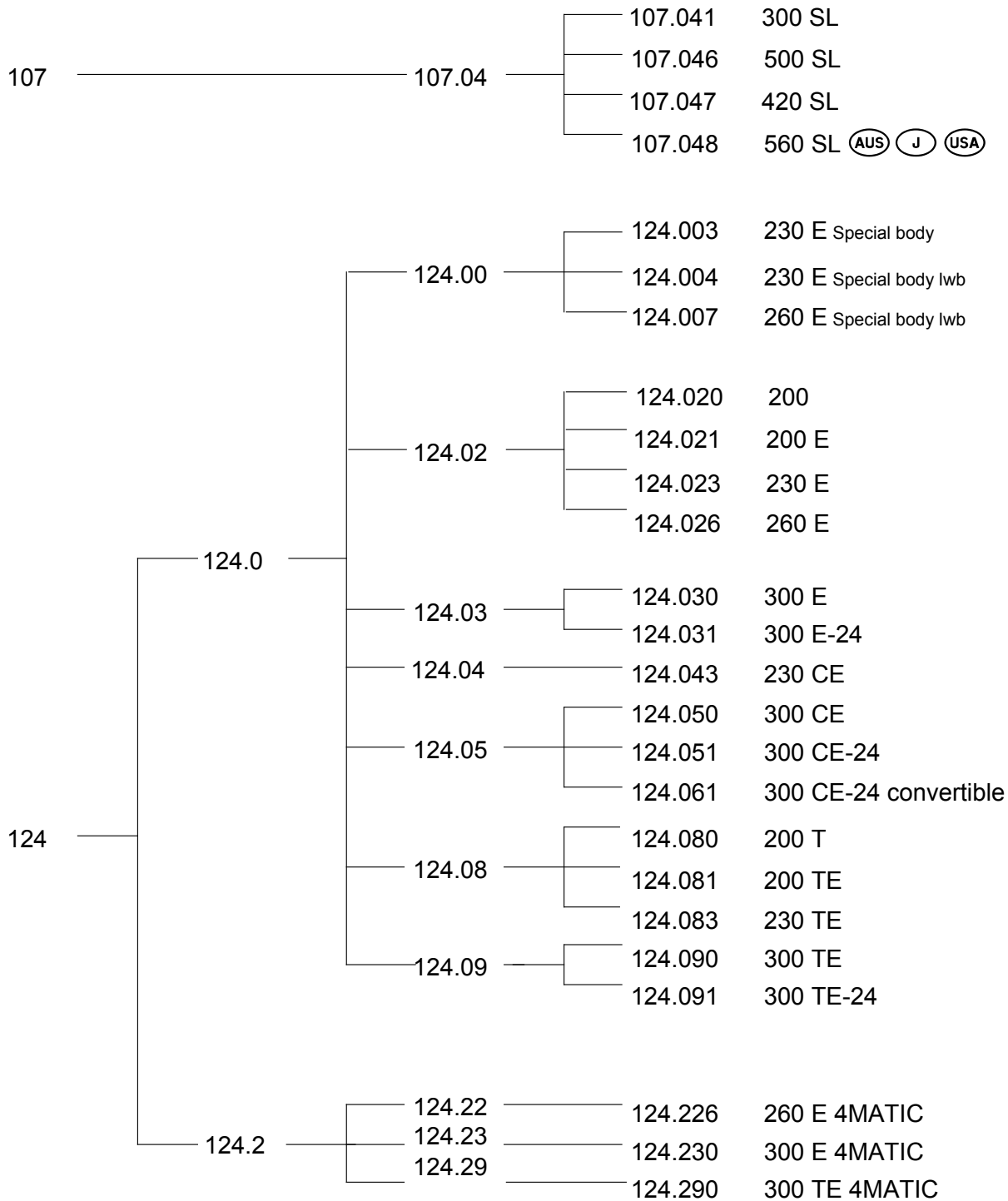

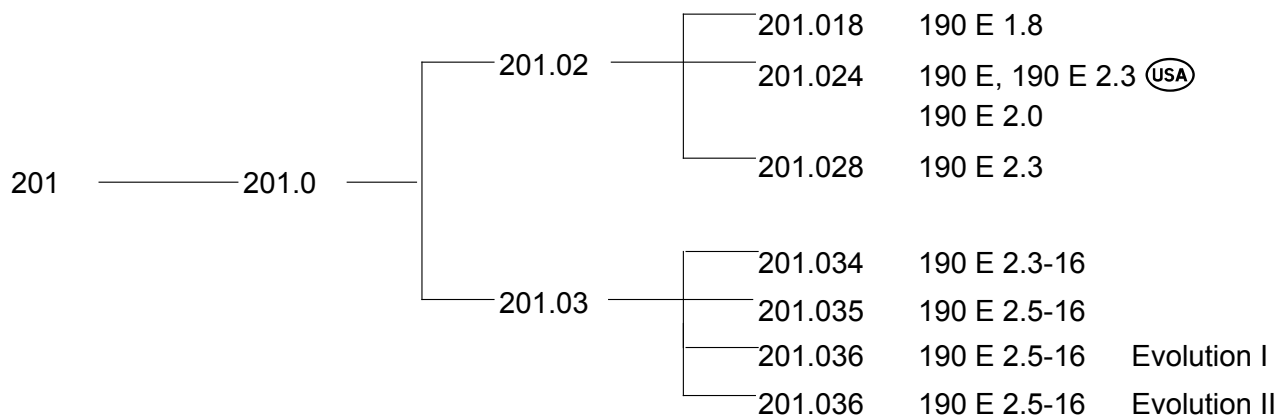
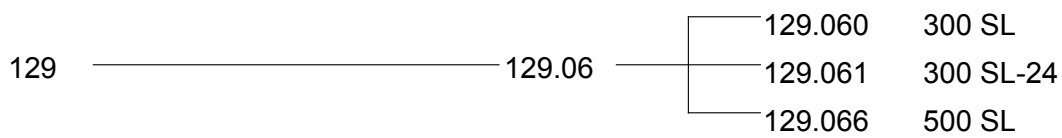
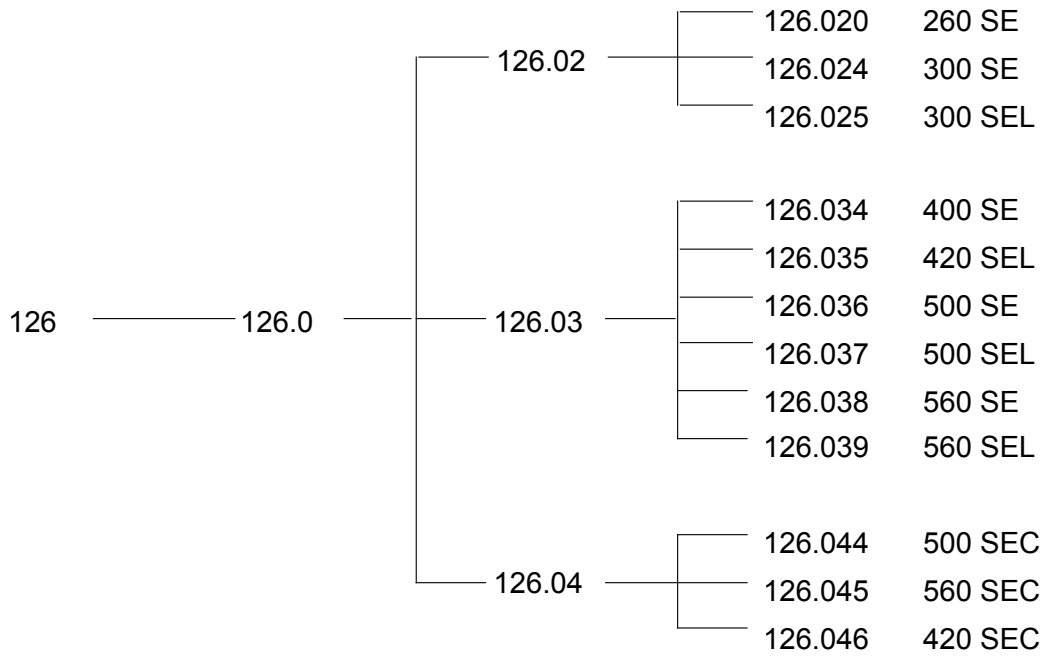

## B. Components survey

### a) 4-cylinder engines

Sales designation	Model	Engine	manufactured from - to
-------------------	-------	--------	------------------------

It's a preview. You can download the full file by clicking the link below.

<https://shopservicemanual.com/>

Service Manuals from 2\$