

SERVICE MANUAL

TD4020F / TD4030F / TD4040F
Tractors

Print No. 84285927

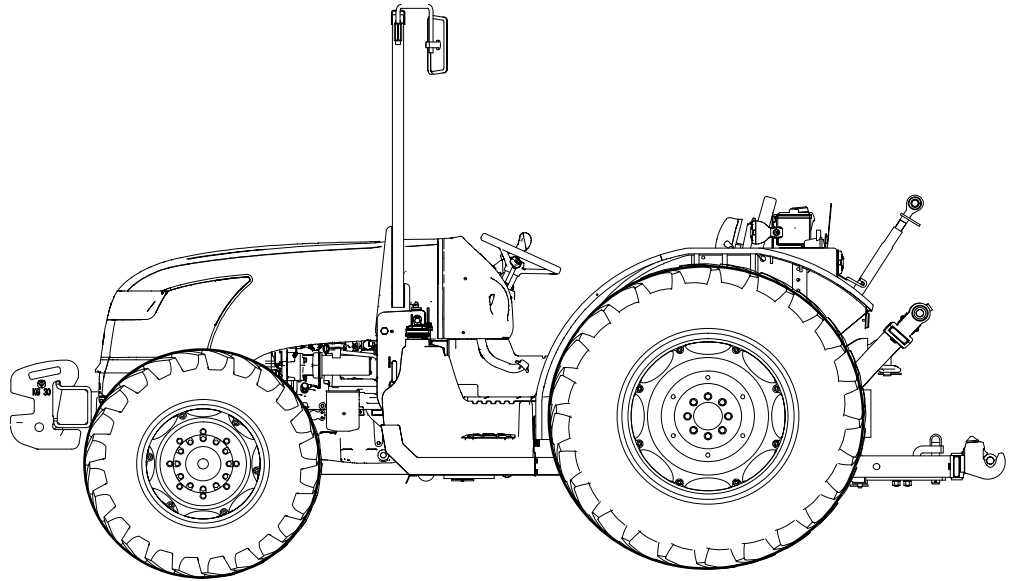



TD4020F – TD4030F – TD4040F

MODEL TRACTORS SERVICE MANUAL

SECTIONS

GENERAL	00
ENGINE	10
CLUTCH	18
GEARBOX	21
TRANSMISSION OF MOTION	23
FRONT MECHANICAL TRANSMISSION	25
REAR MECHANICAL TRANSMISSION	27
POWER TAKE-OFF	31
BRAKES	33
HYDRAULIC SYSTEMS	35
STEERING	41
ELECTRICAL SYSTEM	55

S E R V I C E

INTRODUCTION

- ◇ *This manual is divided into sections identified by two-figure numbers. Each section has independent page numbering.
For ease of reference, these sections have the same numbers and names as the Repairs Rate Book sections.*
- ◇ *The different sections can easily be found by consulting the table of contents on the following pages.*
- ◇ *The document number of the manual and the edition/update dates are given at the bottom of each page.*
- ◇ *The information contained in this manual was current on the date printed on each section. As NEW HOLLAND constantly improves its product range, some information may be out of date subsequent to modifications implemented for technical or commercial reasons or to meet legal requirements in different countries.
In the event of conflicting information, consult the NEW HOLLAND Sales and Service Departments.*

IMPORTANT WARNINGS

- ◇ *All maintenance and repair work described in this manual must be performed exclusively by NEW HOLLAND service technicians in strict accordance with the instructions given and using any specific tools necessary.*
- ◇ *Anyone who performs the operations described herein without strictly following the instructions is personally responsible for resulting injury or damage to property.*
- ◇ *The Manufacturer and all organisations belonging to the Manufacturer's distribution network, including but not restricted to national, regional or local distributors, will accept no responsibility for personal injury or damage to property caused by abnormal function of parts and/or components not approved by the Manufacturer, including those used for maintenance and/or repair of the product manufactured or marketed by the Manufacturer.
In any case, the product manufactured or marketed by the Manufacturer is covered by no guarantee of any kind against personal injury or damage to property caused by abnormal function of parts and/or components not approved by the Manufacturer.*

TEXT AND ILLUSTRATIONS ARE THE PROPERTY
OF NEW HOLLAND



No part of the text or illustrations
may be reproduced

PRINTED IN TURKEY

NEW HOLLAND
SERVICE – Technical Publications & Special Tools
Part no.

NEW HOLLAND

Repair Manual – TD F Series Tractors

CONTENTS

GENERAL

SECTION 00

General Instructions and Health and Safety

Chapter 1

Section	Description	Page
00 000	General instructions	1
	Notes for spare parts	2
	Notes for equipment	2
	Safety rules	3
	Consumables	6

ENGINE

SECTION 10

Engine System

Chapter 1

Section	Description	Page
	Tools	2
	Engine Troubleshooting	5
10 001 10	Engine R.I.	9

CLUTCH

SECTION 18

Clutches

Chapter 1

Section	Description	Page
18 000	General specifications	1
	Torque settings	2
	Tools	3
	Section views	3
	Troubleshooting	5
18 110 10	Clutch – Removal–Installation	6
18 110 30	Dual disk clutch 11”/11” Test bench overhaul	16
18 100 40	Clutch adjustments	24

GEARBOX

SECTION 21

Mechanical Transmission (12x12)

Chapter 1

Section	Description	Page
21 000	Main data	1
	Tightening torques	2
	Tools	3
	Section views	3&5
	Description and operation	8
	Fault diagnosis	8
21 110	Removal – Refitting	see sect 27

Reverser

Chapter 2

Section	Description	Page
21 000	Main data	1
	Tightening torques	2
	Tools	3
	Section views	3
	Description and operation	5
	Fault diagnosis	5
21 110	Removal–Refitting	6

Reverser and Creeper

Chapter 3

Section	Description	Page
21 000	Main data	1
	Tightening torques	2
	Tools	3
	Section views	4
	Description and operation	6
	Fault diagnosis	6
21 110	Removal–Refitting	7

DRIVE LINES

SECTION 23

Drive Lines

Chapter 1

Section	Description	Page
23 000	Main specification	1
	Torque settings and Tools	3
	Cross–Sectional views	4
	Transmission shafts and guard (Disassembly – Assembly)	10
23 101 26	Drive gear housing (Removal – Installation)	11
23 101 40	Drive gear housing removed (Disassembly – Assembly)	13

It's a preview. You can download the full file by clicking the link below.

<https://shopservicemanual.com/>

Service Manuals from 2\$