

# 2012 FLHXSE3 Parts Catalog

Alphabetical List

Parts

Hardware List

New Parts List

Numerical Index

Component Types and Introduction Dates

Common Service Parts

AIR CLEANER

AIR CLEANER COVER

AIR FILTER, ENGINE

ALTERNATOR & REGULATOR

ANTENNA

BACKREST, PASSENGER

BATTERY

BATTERY CABLES

BELT, CHAINS & SPROCKETS

BELT, REAR 140T

BRAKE CALIPER, FRONT

BRAKE CALIPER, REAR

BRAKE CONTROL, FRONT

BRAKE CONTROL, REAR

BRAKE DISC, FRONT

BRAKE DISC, REAR

BRAKE LEVER, FRONT

BRAKE LEVER, REAR

BRAKE LINES & MODULE, REAR - ABS

BRAKE LINES, FRONT - ABS

BRAKE MASTER CYLINDER, FRONT

BRAKE MASTER CYLINDER, REAR

BRAKE MODULE, ABS

CAMSHAFT SUPPORT ASSEMBLY

CAMSHAFTS & CAMSHAFT COVER - TWIN CAM 110™

CHAIN, PRIMARY

CLUTCH

CLUTCH CABLE

CLUTCH CONTROL

CLUTCH CONTROL HAND LEVER

CONSOLE, FUEL TANK

COVER, FUSE

COVER, PUSH RODS

CRANKCASE & ENGINE OIL FILTER - TWIN CAM 110™

CRANKCASE - TWIN CAM 110™

CYLINDER HEADS

CYLINDERS, HEADS & VALVES - TWIN CAM 110™

DIPSTICK

ELECTRONIC CONTROL MODULE (ECM) & COIL

ENGINE ASSEMBLY - TWIN CAM 110™  
ENGINE MOUNTS & STABILIZER LINK  
EVAPORATIVE EMISSIONS COMPONENTS  
EXHAUST SYSTEM  
FAIRING LOWERS  
FAIRING, INNER  
FAIRING, OUTER  
FENDERS, FRONT  
FENDERS, REAR  
FLYWHEEL  
FOOTBOARDS  
FOOTPEGS  
FORK BRACKETS, FRONT  
FORK, FRONT  
FORK, REAR  
FRAME & FORK, REAR  
FRAME & JIFFY STAND (1 OF 2)  
FRAME & JIFFY STAND (2 OF 2)  
FRAME, MAIN  
FRAME, REAR  
FUEL FILTER  
FUEL INJECTOR  
FUEL PUMP  
FUEL TANK  
FUSE, 15 AMP  
FUSE, 30 AMP  
FUSE, MAXI 40 AMP  
GAUGE, FUEL  
GAUGE, VOLTMETER  
GRIPS, HANDLEBAR  
GUARD, ENGINE  
GUARDS, SADDLEBAG  
HANDLEBAR  
HEADLAMP  
HORN  
INDUCTION MODULE, FUEL  
ISOLATOR, REAR WHEEL  
JET, PISTON COOLING  
JIFFY STAND  
LABELS  
LICENSE PLATE BRACKET  
LIFTER, HYDRAULIC  
LOCK SET, COMPLETE  
LOCK SET, COMPLETE  
LOCK, SADDLEBAG  
MIRRORS  
MODULE, SECURITY SYSTEM  
MODULE, TURN SIGNAL CANCELLER  
MUFFLER  
OIL COOLER  
OIL FILTER, ENGINE

OIL PAN, TRANSMISSION  
OIL PUMP - TWIN CAM 110™  
PISTONS & FLYWHEEL ASSEMBLY - TWIN CAM 110™  
PRIMARY COVER  
PRIMARY HOUSING  
PUSH RODS  
RADIO CONTROL, PASSENGER  
REGULATOR, VOLTAGE  
RELAY, HIGH CURRENT  
ROCKER ARM ASSEMBLY & PUSH RODS - TWIN CAM 110™  
ROTOR, ENGINE  
SADDLEBAGS (1 OF 2)  
SADDLEBAGS (2 OF 2)  
SEAT  
SENDER, OIL PRESSURE  
SENSOR, AIR TEMPERATURE  
SENSOR, CRANKSHAFT POSITION  
SENSOR, ENGINE TEMPERATURE  
SENSOR, SPEED  
SENSOR, TEMPERATURE MANIFOLD ABSOLUTE  
SENSORS & SWITCHES, ENGINE  
SHIFTER CAM  
SHIFTER FORK  
SHIFTER, GEAR  
SHOCK ABSORBERS, REAR  
SOLENOID, AUTO COMPRESSION RELEASE  
SOUND SYSTEM (1 OF 2)  
SOUND SYSTEM (2 OF 2)  
SPARK PLUGS  
SPEAKERS  
SPEEDOMETER & TACHOMETER  
SPROCKET, REAR 68T  
SPROCKET, REAR 68T  
SPROCKET, TRANSMISSION 32T  
STABILIZER LINK, ENGINE  
STARTER MOTOR  
STATOR  
SWITCH, ACCESSORY  
SWITCH, AUDIO CONTROL  
SWITCH, CRUISE CONTROL  
SWITCH, CRUISE CONTROL  
SWITCH, IGNITION  
SWITCH, NEUTRAL INDICATOR  
SWITCH, TURN SIGNAL CANCEL  
SWITCHES (1 OF 2)  
SWITCHES (2 OF 2)  
SWITCHES, HANDLEBAR  
TAIL LAMP & TURN SIGNALS, REAR  
TAIL LAMP - CANADA, HDI, ENGLAND, & JAPAN  
TAIL LAMP  
THROTTLE CONTROL

TIRE, FRONT  
TIRE, REAR  
TRANSMISSION BEARINGS & COVERS  
TRANSMISSION GEARS  
TRANSMISSION HOUSING, TOP COVER & OIL PAN  
TRANSMISSION  
TRANSMISSION  
TURN SIGNALS, FRONT  
VALVES  
WHEELS, FRONT  
WHEELS, REAR  
WINDSHIELD, FAIRING & HEADLAMP (1 OF 2)  
WINDSHIELD, FAIRING & HEADLAMP (2 OF 2)  
WIRING HARNESS, INTERCONNECT (1 OF 2)  
WIRING HARNESS, INTERCONNECT (2 OF 2)  
WIRING HARNESS, MAIN, ABS (1 OF 5)  
WIRING HARNESS, MAIN, ABS (2 OF 5)  
WIRING HARNESS, MAIN, ABS (3 OF 5)  
WIRING HARNESS, MAIN, ABS (4 OF 5)  
WIRING HARNESS, MAIN, ABS (5 OF 5)  
Parts

## **ENGINE ASSEMBLY - TWIN CAM 110™**

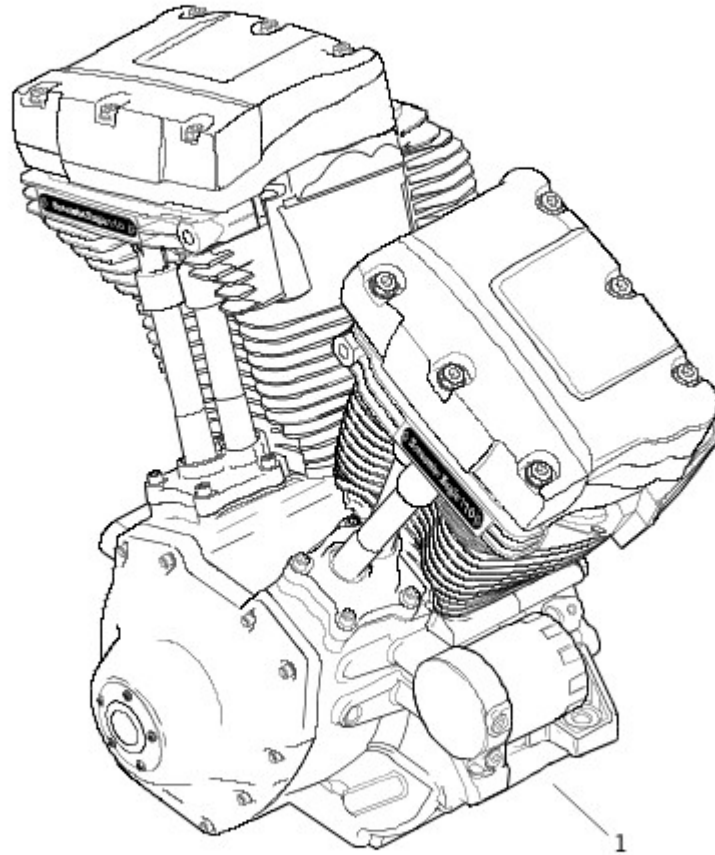
**ENGINE ASSEMBLY**

[View interactive image](#)

[View interactive table](#)

INDEX NO.	PART NO.	DESCRIPTION	MODEL(S)
	19838-12	ENGINE ASSEMBLY, complete - 110 cubic inch (granite/chrome)	FLHXSE3

## CYLINDERS, HEADS & VALVES - TWIN CAM 110™

It's a preview. You can download the full file by clicking the link below.

<https://shopservicemanual.com/>

Service Manuals from 2\$